



BOARD OF TRUSTEES MEETING

Monday, September 8th, 2025, at 6:30pm

Please silence cell phones and electronics.

Zoom Meeting is available as a courtesy for viewing purposes only.

MEETING INFORMATION

The public may dial in or download the Zoom meeting app to access the Board of Trustees meeting with the following credentials:

Meeting ID: 916 3176 7285

Phone: +1 929 205 6099

Password: 059138.

CALL TO ORDER

PLEDGE OF ALLEGIANCE

WELCOME

The purpose of this meeting is to conduct the business of Bath Township. At the end of the meeting there will be time for citizen comments.

APPROVAL OF AGENDA

Fiscal Officer Laura Tuttle

Report / Recommendations

1. Recommendation to approve regular purchase orders 2025-01102 through 2025-01138 and payments in the amount of \$118,036.79.
Included in the payments are the following:
 - \$10,000 to iWorq Systems for the initial set-up and annual TextMyGov communication services fee (Admin)
 - \$35,000 to Richfield Village for School Resource Officer (SRO) share (Admin)

Roll Call

2. Recommendation to approve meeting minutes for May 27th and July 7th, 2025, Special Meetings.
3. Recommendation to approve meeting minutes for the July 28th, 2025, Regular Meeting.
4. Correspondence log is available for public view.

DEPARTMENT HEADS AND ADMINISTRATORS

Police Chief Vito F. Sinopoli
Report / Recommendations

Assistant Fire Chief John Rodriguez
Report / Recommendations

1. Recommendation to accept the new Ohio Billing contract.

Service Director Caine Collins
Report / Recommendations

1. Recommendation to sell the following items through internet auction on GovDeals.com:
 - 2005 International Model 7400 Truck
 - Tippmann propane post pounder
 - Woods 3 point 6' brush hog
 - OTC Dual-Wheel Tire Dolly
 - Hydraulic log splitter attachment for Skid Steer
 - Tailgate and rear bumper for 2019 Ford F-350
 - Set of 4: ITP off-road tires on aluminum wheels
 - 33 Motorola radios and hardware
 - Land Pride 3-point Auger

Parks Director Jeff France
Report / Recommendations

Planning Director / Zoning Inspector William Funk
Report / Recommendations

Administrator Vito F. Sinopoli
Report / Recommendations

1. Recommendation to approve the donation of \$1000 from the H.E. Graves, Jr. Family Foundation to the Bath Police Department for equipment and/or training needs.
2. Recommendation to contract with Hummel Construction Company for the Bath Township North Fork Preserve Barn Project, in the amount of \$1,489,130.00, which includes the Base and Alternate #1.

TRUSTEES: Elaina Goodrich, Sharon Troike, and Sean Gaffney

COMMUNITY UPDATES

1. Bath Park Board – Kathy Sidaway

FUTURE TRUSTEE MEETINGS AND EVENTS

Heritage Corridors of Bath	September 10, 2025, 4:30pm	Trustee Conference Room
Zoning Commission	September 11, 2025, 6pm	Trustee Meeting Room
Water and Sewer District Board	September 15, 2025, 6pm	Trustee Conference Room
Board of Zoning Appeals	September 16, 2025, 7pm	Trustee Meeting Room
Heritage Corridors of Bath Barn Social	September 17, 2025, 6-8pm	Shade Tree Farm

Park Board	September 18, 2025, 6pm	Trustee Meeting Room
Board of Trustees Meeting	September 22, 2025, 4pm	Trustee Meeting Room
Fall into Nature	October 4, 2025, 11-3pm	University of Akron Field Station at Bath Nature Preserve
Appearance Review Commission	October 6, 2025, 5pm	Trustee Meeting Room
Board of Trustees Meeting	October 6, 2025, 6:30pm	Trustee Meeting Room
Zoning Commission	October 9, 2025, 6pm	Trustee Meeting Room

*A full list of events and meetings is posted to www.bathtownship.org and updated weekly.

CITIZENS' COMMENTS

Citizens must be recognized by the President of the Board of Trustees prior to speaking.

Citizens will identify themselves by name and address.

Citizens' comments will be limited to 5 minutes each.

Citizens' comments must be addressed to the Board.

A citizen is called out of order twice. He or she will then be asked to leave.

THANK YOU FOR ATTENDING / ADJOURNMENT

Bath Township Check Register

Check Number	Check Date	Vendor Code	Vendor Name	Payment Type	Amount
000000695	09/08/2025	02920	AMAZON CAPITAL SERVICES	ACH VENDOR PAY	\$3,684.64
000000696	09/08/2025	people check	PEOPLE CHECK LLC	ACH VENDOR PAY	\$124.00
000000697	09/08/2025	02532	FIRE FORCE INC	ACH VENDOR PAY	\$60.40
000000698	09/08/2025	charter communicati	CHARTER COMMUNICATION - INTERNE	ACH VENDOR PAY	\$399.00
000000699	09/08/2025	00019	BARBERTON LAUNDRY AND CLEANING	ACH VENDOR PAY	\$276.35
000000700	09/08/2025	01404	NMJ TECHNOLOGY LLC	ACH VENDOR PAY	\$3,545.07
000000701	09/08/2025	forerunner technologi	FORERUNNER TECHNOLOGIES INC	ACH VENDOR PAY	\$36.65
000000702	09/08/2025	00079	DYNAMERICAN	ACH VENDOR PAY	\$260.00
000000703	09/08/2025	01808	FALLSWAY EQUIPMENT CO INC	ACH VENDOR PAY	\$2,150.00
000000704	09/08/2025	00380	GARDINER SERVICE COMPANY, LLC	ACH VENDOR PAY	\$6,243.00
000000705	09/08/2025	00508	BERES, KAREN	ACH VENDOR PAY	\$249.78
000000706	09/08/2025	00745	CUYAHOGA LANDMARK INC	ACH VENDOR PAY	\$3,535.20
000000707	09/08/2025	01164	IWORQ SYSTEMS INC	ACH VENDOR PAY	\$10,000.00
000000708	09/08/2025	01863	MASTHEAD HOLDINGS LLC	ACH VENDOR PAY	\$73.26
000000709	09/08/2025	02536	SHELLY MATERIALS INC	ACH VENDOR PAY	\$485.47
000000710	09/08/2025	akron canton waste o	ECO-MAXX FLUID RESOURCES LLC	ACH VENDOR PAY	\$140.00
000000711	09/08/2025	marlboro supply	MARLBORO SUPPLY	ACH VENDOR PAY	\$3,916.30
000000712	09/08/2025	00960	LEPPO INC	ACH VENDOR PAY	\$709.50
000000713	09/08/2025	01178	MAR-ZANE INC	ACH VENDOR PAY	\$3,597.30
Grand Total:			Number Of Checks: 19		\$39,485.92

Bath Township Check Register

Check Number	Check Date	Vendor Code	Vendor Name	Payment Type	Amount
0000065575	09/08/2025	01142	3R SALES & SERVICE	Checks for 0001	\$212.03
0000065576	09/08/2025	00993	AKRON PUBLIC UTILITIES BUREAU	Checks for 0001	\$339.59
0000065577	09/08/2025	02562	ALLIED CORP INC	Checks for 0001	\$2,129.95
0000065578	09/08/2025	at&t mobility national	AT&T MOBILITY II, LLC	Checks for 0001	\$2,022.31
0000065579	09/08/2025	01588	BATH TRACTOR	Checks for 0001	\$194.95
0000065580	09/08/2025	brightview	BRIGHTVIEW LANDSCAPES LLC	Checks for 0001	\$11,522.13
0000065581	09/08/2025	rudy christian	CHRISTIAN & SON INC	Checks for 0001	\$300.00
0000065582	09/08/2025	01317	CORE & MAIN LP	Checks for 0001	\$480.64
0000065583	09/08/2025	01901	FRONTIER TANK CENTER INC	Checks for 0001	\$259.08
0000065584	09/08/2025	00236	GALLS INC	Checks for 0001	\$244.09
0000065585	09/08/2025	01148	GC MEDICAL EQUIPMENT INC	Checks for 0001	\$97.17
0000065586	09/08/2025	genuine parts compa	GENUINE PARTS COMPANY INC	Checks for 0001	\$1,224.16
0000065587	09/08/2025	02755	HEIDI'S TOWING	Checks for 0001	\$188.00
0000065588	09/08/2025	01791	HOWELL RESCUE SYSTEMS	Checks for 0001	\$900.00
0000065589	09/08/2025	maureen katanic	KATANIC, MAUREEN G.	Checks for 0001	\$55.39
0000065590	09/08/2025	00101	LEVINSONS UNIFORMS	Checks for 0001	\$315.00
0000065591	09/08/2025	01806	LOWES COMPANIES	Checks for 0001	\$1,232.37
0000065592	09/08/2025	medical mutual	Medical Mutual	Checks for 0001	\$3,409.63
0000065593	09/08/2025	01163	MEDPRO DISPOSAL	Checks for 0001	\$106.04
0000065594	09/08/2025	00111	MONTROSE FORD	Checks for 0001	\$1,162.47
0000065595	09/08/2025	03024	Elizabeth H. Drews	Checks for 0001	\$290.00
0000065596	09/08/2025	03024	Dennis Przykuta	Checks for 0001	\$50.00
0000065597	09/08/2025	00907	ORION SAFETY PRODUCTS	Checks for 0001	\$872.50
0000065598	09/08/2025	00050	OTIS ELEVATOR COMPANY	Checks for 0001	\$1,356.24
0000065599	09/08/2025	00731	POLY TECH ASSOC INC	Checks for 0001	\$1,095.00
0000065600	09/08/2025	00631	QUADIENT FINANCE USA INC	Checks for 0001	\$300.00
0000065601	09/08/2025	02210	RICHFIELD AUTO PARTS	Checks for 0001	\$89.40
0000065602	09/08/2025	02298	RICHFIELD VILLAGE	Checks for 0001	\$35,000.00
0000065603	09/08/2025	shega, tim	SHEGA, TIM	Checks for 0001	\$250.00
0000065604	09/08/2025	02800	SUNDANCE SYSTEMS INC	Checks for 0001	\$1,200.00
0000065605	09/08/2025	00399	THE APOSTOLOS GROUP INC	Checks for 0001	\$200.00
0000065606	09/08/2025	01813	THE DAVEY TREE EXPERT CO	Checks for 0001	\$1,490.00
0000065607	09/08/2025	transunion	TRANSUNION RISK & ALTERNATIVE DA	Checks for 0001	\$100.00
0000065608	09/08/2025	treas of state of ohio	TREASURER OF STATE OF OHIO	Checks for 0001	\$125.00
0000065609	09/08/2025	treasurer state of ohi	TREASURER STATE OF OHIO	Checks for 0001	\$138.00
0000065610	09/08/2025	01420	UNITED RENTALS	Checks for 0001	\$280.00
Grand Total:			Number Of Checks: 36		\$69,231.14

Bath Township Check Register

Check Number	Check Date	Vendor Code	Vendor Name	Payment Type	Amount
000000812	09/08/2025	00166	ENBRIDGE GAS OHIO	EFT for 0001-TRUST	\$461.39
000000813	09/08/2025	00015	OHIO EDISON	EFT for 0001-TRUST	\$8,858.34
Grand Total:			Number Of Checks: 2		\$9,319.73

**BATH TOWNSHIP BOARD OF TRUSTEES
CORRESPONDENCE LOG**

DATE	RECEIVED FROM	SUBJECT MATTER	REFERRED TO:
9.4.25	Alan Kurzweil	Courts	Township Trustees
9.4.25	Timothy Franklin	BZA Site Visits Reminder	Township Trustees
9.6.25	Chuck Gray	Text Correspondence Regarding Courts	Trustee Goodrich
9.8.25	Chuck Gray	Pickleball	Trustee Goodrich
9.6.25	Mark Frey	BCF \$ for AM250	Trustee Goodrich
9.6.25	Jody Konstand	Fwd_ BCF \$ for AM250	Trustee Goodrich

Chief of Police Report September 8, 2025

Department Trainings:

Officer Chapman – Firearms & Explosives Police Rifle Carbine Instructor 8/12-15/2025

Officer Pemberton – Crisis Intervention Team Training 8/25-29/2025

Sgt. Shaffer – FBI-LEEDA Executive Leadership Training 8/25-29/2025

Digital Photography for Law Enforcement Level I, August 19-21, 2025, conducted by the Federal Law Enforcement Training Center (FLETC). Our department hosted the training, and both Detectives Young and Reilly attended.

Department Highlights:

Ohio Association of Chiefs of Police (OACP) presented an award to Bath resident, Mike Ayers, in appreciation for his work with the Sisler-McFawn Foundation and the Foundation's support for the educational initiatives of OACP on August 19, 2025.

Chief Sinopoli emphasized the importance of the safety component for pedestrians in completing the sidewalk corridor on Cleveland-Massillon Road at the ribbon-cutting ceremony at Lowe's on August 25, 2025.

Chief Sinopoli gave a department tour to a young man on August 29, 2025.

August Statistics:

All Calls for Service 1,813 [100%]

Community Policing 1,235 [68%]

Traffic Stops 60 [3%]

Traffic Accidents 52 [3%]

Alarm Drops 39 [2%]

Sexual Offense 0 Robbery 0 Burglary 0

All other calls for service: 427 [24%]

Booking Charges [Total] 16

OVI 2

Theft 2

Failure to Appear; Issuance of Warrant 3

Recommendations:

None.

To: Bath Township Trustees – Sean Gaffney, Elaina Goodrich and Sharon Troike
Fiscal Officer – Laura Tuttle
Bath Administrator - Vito Sinopoli

From: John Rodriguez, Assistant Fire Chief

Date: September 8, 2025

August 2025 Calls

Station 1 =80
Station 2 = 75
All Stations = 6
Total = 161

EMS = 106
Fire = 55

Total Transports = 68

Mutual Aid Given= 13
Mutual Aid Received= 7

Yearly Call Total: 1,268
EMS = 856
FIRE =412

TRAINING:
Classes = 5
Hours = 10.5

INSPECTIONS:

Annual	20
Consult	1
Plan Review	2
Reinspection	3
Knox Box	1
Home Inspection	1
TOTAL	<hr/> 28

REPORT:
Station tour.

RECOMMENDATIONS:

1. Recommendation to accept the new Ohio Billing contract.

BUSINESS ASSOCIATE AGREEMENT

This Business Associate Agreement (“Agreement”) is made the day of _____, 2025 (the “Effective Date”), by and between **Bath Township dba: Bath Township Fire Department** (“Provider”) and Ohio Billing, Inc. (“Business Associate”). Provider and Business Associate may be referred to herein, each individually as a “Party” or jointly as the “Parties.”

Background

A. Provider is a healthcare provider as that term is defined in the Privacy Rule (45 C.F.R. Part 160 and Part 164) and the Security Standards (45 C.F.R. Part 160, Part 162, and Part 164), as promulgated under the Health Insurance Portability and Accountability Act of 1996, Pub. L. No. 104-191 (“HIPAA”) and the Health Information Technology for Economic and Clinical Health Act (“HITECH”), as amended from time to time. According to the Privacy Rule, the Provider is under an affirmative obligation to protect the privacy of Protected Health Information (“PHI”) that it creates or receives while fulfilling its professional obligations. According to the Security Standards, the Provider may not disclose PHI unless it obtains satisfactory assurances that the party to whom it discloses the PHI will appropriately safeguard the information.

B. Provider wishes to disclose PHI to Business Associate because Business Associate, on behalf of Provider, performs a function of Provider’s health care operations, namely, the management and processing of Provider’s billings and accounts receivables, including but not limited to, claims processing, claims administration and billing services (collectively “Services”). Provider may disclose PHI to a Business Associate for purposes of the stated function only if the Business Associate signs a contractual agreement with Provider stating that the Business Associate will appropriately safeguard the PHI.

C. Both parties are committed to compliance with the Privacy Rule, the Security Standards, and HITECH. This Agreement is intended to set forth the terms and conditions under which PHI that is provided by, or created or received by, Business Associate from or on behalf of Provider, will be handled to promote and ensure such compliance.

NOW, THEREFORE, in consideration of the premises and mutual covenants contained herein, the parties hereto, intending to be legally bound hereby, agree as follows:

1. **Definitions.** Capitalized terms used but not otherwise defined in this Agreement shall have the same meaning as those terms are defined in final regulations relating to privacy and security of individually identifiable health information at 45 CFR Parts 160, 162, and 164 implementing HIPAA and HITECH, as amended from time to time.

1.1. Breach Notification Rule: means the final regulatory provisions set forth at 45 CFR Subtitle A, Subchapter C, Parts 160 and 164, Subparts A and D.

1.2. Compliance Date: means the later of (1) the date that compliance is required under the relevant provision of the HIPAA Rules, and (2) the date this Agreement takes effect between the Parties.

1.3. HIPAA Rules: means, collectively, the Breach Notification Rule, Privacy Rule, and Security Rule.

1.4. Individual: has the same meaning as in the HIPAA Rules, as well as a person who qualifies as a personal representative following the HIPAA Rules.

1.5. Internal Material: means Business Associate's documented internal practices, books, and records, including policies and procedures relating to the use and disclosure of PHI created, received, maintained, or transmitted by, Business Associate for or on behalf of Customer.

1.6. Privacy Rule: means final regulatory provisions set forth at 45 CFR Subtitle A, Subchapter C, Parts 160 and 164, Subparts A and E.

1.7. Protected Health Information or PHI, Electronic Protected Health Information or ePHI: have the same meaning as "protected health information" and "electronically protected health information" in the HIPAA Rules, but limited to the information created, received, maintained, or transmitted by Business Associate for or on behalf of Customer in the performance of the Services.

1.8. Security Rule: means final regulatory provisions set forth at 45 CFR Subtitle A, Subchapter C, Parts 160 and 164, Subparts A and C.

2. Permitted Uses and Disclosures by Business Associate.

2.1. **General Use and Disclosure.** Except as otherwise limited in this Agreement, Business Associate may use or disclose PHI solely (1) as necessary to provide the Services to Customer and in compliance with each applicable requirement of 45 CFR § 164.504(e), (2) as required by law, (3) as expressly otherwise authorized under this Agreement, or (4) to perform functions, activities, or services for, or on behalf of, Provider as specified in the Processing Agreement in effect between Business Associate and Provider (the "Processing Agreement"), provided that such use or disclosure would not:

2.1.1. Violate the Privacy Rule if done by Provider.

2.1.2. Violate the Security Standards if done by Provider; or

2.1.3. Violate the minimum necessary policies and procedures of Provider.

2.2. Specific Use and Disclosure.

2.2.1. **Use.** Except as otherwise limited in this Agreement, Business Associate may use PHI for its proper management and administration, or to carry out or fulfill any present or future legal responsibilities of Business Associate.

2.2.2. **Disclosure.** Except as otherwise limited in this Agreement, Business Associate may disclose PHI for its proper management and administration, or to carry out or fulfill any present or future legal responsibilities of Business Associate. Business Associate represents to Provider that (i) it will only make those disclosures permitted under applicable laws, and (ii) Business Associate will obtain reasonable assurances from the person to whom the information is disclosed that the PHI will remain confidential and used or further disclosed only as required by law or for the purpose for which it was disclosed to the person, and the person agrees to notify Business Associate of any instances of which it is aware in which the confidentiality of the information has been breached. Any disclosure of PHI by Business Associate under this provision will not create a subcontractor relationship with the entity to which the disclosure is made and the Business Associate will not be required to obtain a Business Associate agreement with such entity.

2.2.3. **Data Aggregation.** Except as otherwise limited in this Agreement, Business Associate may use PHI to provide data aggregation services to Provider related to Provider's healthcare operations, as permitted by 42 C.F.R. § 164.504(e)(2)(i)(B).

2.2.4. **De-Identified Information.** Except as otherwise limited in this Agreement, the Business Associate may de-identify any PHI, provided that the de-identification conforms to the requirements of applicable law as provided for in 42 C.F.R. § 164.514(b) and that the Business Associate maintains such documentation as required by applicable law. Business Associate and Provider understand that properly de-identified information is not PHI according to 45 C.F.R. § 164.502(d)(2) and therefore is not subject to the terms of this Agreement.

2.3. **Other Uses and Disclosures.** Any use or disclosure by a Business Associate not authorized by this Agreement is hereby prohibited.

3. **Incorporation of Processing Agreement.** The terms of the Processing Agreement are hereby incorporated into this Agreement. In the event of a conflict between the terms of the Processing Agreement and this Agreement, the terms and conditions of this Agreement shall govern.

4. **Obligations and Duties of Business Associate.**

4.1. **Non-Permitted Use or Disclosure.** Business Associate agrees to not use or disclose PHI other than as permitted or required by this Agreement or by applicable state or federal law, as amended from time to time.

4.2. **Safeguards.** Business Associate agrees to implement administrative, physical, and technical safeguards that reasonably and appropriately protect the confidentiality, integrity and

availability of PHI in electronic form that Business Associate creates, receives, maintains or transmits on behalf of the Provider as required by the Security Standards. Such safeguards shall also prevent use or disclosure of the PHI other than as provided for by this Agreement.

4.3. **Mitigation.** Business Associate agrees to mitigate, to the extent practicable, any harmful effect that is known to Business Associate of a use or disclosure of PHI by Business Associate in violation of the requirements of this Agreement.

4.4. **Required Reports.**

4.4.1. **Non-Permitted Use or Disclosure.** Business Associate agrees to report to Provider any use or disclosure of the PHI not provided for by this Agreement of which it becomes aware, as soon as reasonably possible after becoming aware of such use or disclosure.

4.4.2. **Security Incident.** Business Associate agrees to report to Provider any security incident of which it becomes aware, as soon as reasonably possible after becoming aware of such security incident.

4.5. **Restrictions on Agents.** Business Associate agrees to ensure that any agent, including a subcontractor, to whom it provides PHI received from, or created or received by, Business Associate on behalf of Provider, agrees to the same restrictions and conditions that apply through this Agreement to Business Associate with respect to such information, including but not limited to the implementation of reasonable and appropriate safeguards to protect PHI in electronic form.

4.6. **Compliance.** For purposes of the United States Secretary of Health and Human Services (the "Secretary") determining Provider's compliance with the Privacy Rule and/or Security Standards, Business Associate agrees to make internal practices, books, and records, including PHI and policies and procedures relating to the use and disclosure of PHI received from, or created or received by Business Associate on behalf of, Provider available to Provider, or to the Secretary, in a reasonable time and manner or as designated by the Secretary, subject to any applicable legal privileges.

4.7. **Patient-Requested Accounting.**

4.7.1. **Documentation.** Business Associate agrees to document such disclosures of PHI and information that are not related to Treatment, Payment, or Healthcare Operations, as such terms are defined in the Privacy Rule. The documentation shall include (i) the subject of the PHI (*i.e.*, patient name or identifier), (ii) the PHI disclosed, and (iii) the purpose of the disclosure, following 45 C.F.R. § 164.528.

4.7.2. **Provision.** Business Associate agrees to provide to Provider or a patient of Provider, within twenty (20) days of a written request therefor and reasonably to be agreed upon between the parties, information collected following this Section 4.7, to permit Provider to

respond to a request by a patient of Provider for an accounting of disclosures of PHI following 45 C.F.R. §164.528.

4.8. **Access.** Business Associate agrees to provide access to PHI, at the request of Provider, within five (5) days of a written request therefor and reasonably to be agreed upon between the parties, to Provider or, as directed by Provider, to a patient of Provider to meet the requirements under 45 C.F.R. § 164.524 relating to the right of patients to access their medical records, as necessary. Notwithstanding anything herein to the contrary, this Section 4.8 shall not apply if the Business Associate does not retain PHI in a designated record set.

4.9. **Amendment.** Business Associate agrees to make any amendment(s) to PHI in its possession Provider directs or agrees to according to 45 C.F.R. § 164.526 at the request of Provider or a patient of Provider's, and in a reasonable time and manner to be agreed upon between the parties. Notwithstanding anything herein to the contrary, Section 4.9 shall not apply if the Business Associate does not retain PHI in a designated record set.

5. **Obligations of and Duties of Provider.**

5.1. **Notice of Privacy Practices.** Provider shall include in its Notice of Privacy Practices, as required by the Privacy Rule, a statement that Provider may disclose PHI for purposes of its health care operations. The provider shall be responsible for determining whether uses or disclosures made by or at its direction comply with any limitations in the Customer's Notice of Privacy Practices.

5.2. **Limitation in Notice of Privacy Practices.** The provider shall notify the Business Associate of any limitation(s) in its Notice of Privacy Practices following 45 CFR 164.520, to the extent that such limitation may affect the Business Associate's use or disclosure of PHI. Business Associate may terminate the Agreement if such limitation(s) materially affect Business Associate's ability to perform under the Agreement.

5.3. **Provider Covenants.** Provider shall promptly notify Business associate in writing of any patient-requested restriction to the use or disclosure of PHI that Provider has agreed to follow 45 C.F.R. § 164.522, or any other restrictions on use or disclosure as agreed to by Provider, to the extent that such restriction may affect Business Associate's use or disclosure of PHI or its ability to perform its obligations under this Agreement or the Processing Agreement. Business Associate may terminate the Agreement if such restriction(s) materially affect Business Associate's ability to perform under the Agreement.

5.4. **Impermissible Requests by Provider.** Provider shall not request Business Associate to use or disclose PHI in any manner that would not be permissible under the Privacy Rule and/or Security Standards if done by Provider, except for such uses and disclosures described in Section 2.

5.5. **Patient Amendment of PHI.** Provider shall promptly notify Business Associate of any patient-requested amendment of that patient's PHI if Provider knows that Business Associate has the PHI that is the subject of the amendment, and Business Associate may have relied, or could foreseeably rely, on such PHI to the detriment of the patient.

6. Term and Termination.

6.1. **Term.** The Term of this Agreement shall commence as of the Effective Date and shall terminate upon the termination of the Processing Agreement.

6.2. **Termination for Cause by Provider.** Upon Provider's knowledge of a material breach of this Agreement by Business Associate or a violation by Business Associate of its obligations under this Agreement, Provider shall either:

6.2.1. Give the Business Associate written notice of the existence of the breach or violation and provide the Business Associate with thirty (30) days to cure the breach or end the violation. If Business Associate does not cure the breach or end the violation within these thirty (30) daytimes period, then Provider shall terminate this Agreement, provided, however, that if the breach cannot reasonably be cured within thirty (30) days, then Provider shall extend the time to cure for an additional fifteen (15) days; or

6.2.2. Immediately terminate this Agreement if the Business Associate has breached a material term of this Agreement or violated an obligation under this Agreement and cure is not possible.

If neither termination nor cure is feasible, the Provider has the right to report the violation to the Secretary.

6.3. **Termination for Cause by Business Associate.** Upon Business Associate's knowledge of a material breach by Provider, Business Associate shall either:

6.3.1. Give Provider written notice of the existence of the breach and provide Provider with thirty (30) days to cure the breach or end the violation, and terminate this Agreement if Provider does not cure the breach or end the violation within this thirty (30) day time period, provided, however, that if the breach cannot reasonably be cured within thirty (30) days, then Business Associate shall extend the time to cure for an additional fifteen (15) days; or

6.3.2. Immediately terminate this Agreement if the Provider has breached a material term of this Agreement and cure is not possible.

6.4. Effect of Termination.

6.4.1. Except as provided in Section 6.4.2, upon termination of this Agreement for any reason, the Business Associate shall return or destroy all PHI received from the Provider or

created or received by the Business Associate on behalf of the Provider. This provision shall apply to PHI that is in the possession of subcontractors or agents of the Business Associate. Business Associate shall retain no copies of the PHI.

6.4.2. If the Business Associate determines that returning or destroying the PHI is not feasible, the Business Associate shall provide notification to the Provider that the return or destruction is not feasible. In addition, if the return or destruction of PHI is not feasible, Business Associate shall extend the protections of this Agreement to such PHI and limit further uses and disclosures of such PHI to those purposes that make the return or destruction not feasible, for so long as Business Associate maintains such PHI.

6.4.3. Termination of this Agreement will result in termination of the related Processing Agreement.

7. Mutual Representations and Warranties. Each party to this Agreement (“Party”) represents and warrants to the other Party:

7.1. It is duly organized, validly existing, and in good standing under the laws of the jurisdiction in which it is organized or licensed, it has the full power to enter into this Agreement and to perform its obligations described in this Agreement, and the performance by it of its obligations under this Agreement have been duly authorized by all necessary corporate or other actions and that such performance will not violate any provision of any organizational charter or bylaws.

7.2. Neither the execution of this Agreement, nor its performance, will directly or indirectly violate or interfere with the terms of another agreement to which it is a party, or give any governmental authority the right to suspend, terminate, or modify any of its governmental authorizations or assets required for its performance.

7.3. All its employees, agents, representatives, and members of its workforce, whose services may be used to fulfill obligations under this Agreement, are or shall be appropriately informed of the terms of this Agreement, and are under legal obligation to each Party, respectively, by contract or otherwise, sufficient to enable each Party to fully comply with all the provisions of this Agreement.

7.4. It will reasonably cooperate with the other Party in the performance of the mutual obligations under this Agreement.

8. Limitation of liability. Neither party shall be liable to the other party for any incidental, consequential, special, or punitive damages of any kind or nature, whether such liability is asserted based on contract, tort (including negligence or strict liability), or otherwise, even if the other party has been advised of the possibility of such loss or damages.

9. **Miscellaneous.**

9.1. **Regulatory References.** A reference in this Agreement to a section in the Privacy Rule or Security Standards means the section is in effect or as amended if such amendment is final and the Compliance Date for such amendment has passed.

9.2. **Amendment.** The parties hereto agree to negotiate in good faith to amend this Agreement from time to time as is necessary for the Provider to comply with the requirements of the Privacy Rule and/or the Security Standards of HIPAA and/or HITECH. If the Parties do not reach an agreement as to an appropriate amendment, either Party may terminate this Agreement by giving written notice to the other Party at least sixty (60) days before the proposed termination date. No amendment or modification of any provision of this Agreement shall be binding unless in writing and signed by the parties hereto. If Business Associate determines that it is not reasonably able to comply with any final new or amended provision(s) of the Privacy Rule and/or the Security Standards of HIPAA and/or HITECH, Business Associate may terminate this Agreement (and the Provider Agreement) upon written notice to Provider of at least sixty (60) days.

9.3. **No Third-Party Beneficiaries.** Except as otherwise specifically provided in this Agreement, this Agreement is made for the sole benefit of the parties. No other persons shall have any rights or remedies because of this Agreement against any of the parties or shall be third-party beneficiaries of this Agreement in any way.

9.4. **Survival.** The respective rights and obligations of the Business Associate under Section 6.4 of this Agreement shall survive the termination of this Agreement.

9.5. **Interpretation.** Any ambiguity in this Agreement shall be resolved to permit the Provider and/or Business Associate, as applicable, to comply with the Privacy Rule and Security Standards.

9.6. **Notices.** Any notice or document required or permitted to be given under this Agreement shall be deemed to be given on the date one day after such notice is (i) deposited in the United States mail, postage prepaid, certified mail, return receipt requested, or (ii) deposited with a commercial overnight delivery service with delivery fees paid.

9.7. **Governing Law.** This Agreement shall be governed by the internal laws of the State of Ohio, without giving effect to the principles of conflicts of laws.

9.8. **Signatures.** This Agreement may be signed in counterparts, each of which shall be deemed to be a fully executed original. An original signature transmitted by facsimile shall be deemed to be original for purposes of this Agreement.



9.9. **Assignment.** No party to this Agreement shall assign its rights or duties hereunder without the prior written consent of the other party, except that a party may assign its rights and duties in connection with a sale or other disposition of all or substantially all of its business or assets. Any attempted assignment without such prior written consent shall be null and void.

9.10. **Titles and Captions.** All article, section, and paragraph titles and captions contained in this Agreement are for convenience only and are not deemed a part of the context hereof.

9.11 **Governing Law and Venue.** This Agreement shall be construed under the laws of Ohio. Both parties, by signing this agreement, expressly consent to venue in Tuscarawas County, Ohio, for any litigation resulting from any breach of this agreement.

IN WITNESS WHEREOF, and intending to be legally bound, the parties have duly executed this Agreement on the day of _____, 2025, but effective as of the date set forth above.

**Bath Township dba: Bath Township Fire Department
3864 W. Bath Road
Akron, Ohio 44333-1104**

Print Name/Title

Signature

Witness Print Name/Title

Witness Signature

Ohio Billing, Inc.
PO Box 515
Bolivar, Ohio 44612-0515

Gabrielle Ferguson / Director of Operations

Print Name/Title

Signature

Pamela Sprowls / Director of Business Development

Witness Print Name/Title

Witness Signature

SERVICE DIRECTOR Caine Collins

AGENDA FOR THE TRUSTEE MEETING 9.8.2025

Buildings and Grounds:

No new business to report.

Roads:

Service Crew Monthly Report for August

Resident Service Requests received: 30

Resident Service Requests resolved: 15

Township Service Requests received: 8

Township Service Requests resolved: 7

Right of Way Permits: 1 Residential

Drive Culverts: 3

Asphalt Aprons: 6

Catch Basins: 1

Linear Feet of Ditching: 65'

Approx Tons of Asphalt Used: 143.65

Miscellaneous:

Vehicle Maintenance/Repairs; Shop, Buildings, and Grounds Maintenance/Repairs; Cemetery Maintenance, Restorations, Foundations, and Burial Assistance; Roadway Tree Trimming and Removal; Roadside Mowing; Dead Animal Removal from Township Roadways; Installation and Repairs of Address Markers and Street Signs/Posts; Pothole Patching; Road Repairs; Continuous Cleaning and Sanitizing of Shop and Trucks; Service Request Requests and Restorations; Roadside Sign Removal; Assisted Parks with the Playground Project; and Emptying of the Organic Recycle Trailer.

Training:

Summit County Safety County Monthly Meeting "Heat Stress" – Sean Humphrys

NEO APWA Flagger Training - Ricky Brogan, Greg Klebs, Owen Pasterchek, Doug Fair

Cemetery Burials:

Moore's Chapel: 2 Full Burials & 1 Cremation

Recommendations by the Service Director:

Recommendation to sell the following items through internet auction on GovDeals.com:

2005 International Model 7400 Truck
Tippmann propane post pounder
Woods 3 point 6' brush hog
OTC Dual-Wheel Tire Dolly
Hydraulic log splitter attachment for Skid Steer
Tailgate and rear bumper for 2019 Ford F-350
Set of 4: ITP off-road tires on aluminum wheels
33 Motorola radios and hardware
Land Pride 3-point Auger

BATH PARKS DIRECTOR Jeff France

AGENDA FOR THE TRUSTEE MEETING 9.8.2025

General Park Information:

For the month of August, park personnel checked and inspected all the trails, performed routine inspections on the playgrounds, performed general buildings and grounds maintenance/repairs, and completed vehicle and equipment maintenance/repairs.

Bath Baseball Park:

For the month of August, the ballfields were playable 87% of the time. Records show there was precipitation on 4 days in August, with an approximate total of 0.34 inches.

Bath Community Park:

The Playground expansion continues, with the help of the road department leveling and hauling material to prepare for the new playground area. Myers Design continues to work on the wood timber border. Midstate Recreation is planning on installing equipment sometime in November.

Bath Hill Park:

No new business to report.

Bath Nature Preserve:

I would like to remind residents that Fall into Nature is on October 4th from 11am – 3pm at the Bath Nature Preserve. Park personnel installed new kayak signs throughout the park. They also landscaped and installed a new sign at the entrance of the park.

North Fork Preserve of Bath:

No new business to report

Heritage Corridors Wayside Exhibit:

Parks Personal installed the new Heritage Barns of Bath sign at the Heritage Corridor Wayside Exhibit.

Training

Parks personnel attended the NEO APWA Flagger Training.

Recommendations:

No recommendation at this time



To: Board of Trustees, Fiscal Officer, Administrator, Executive Assistant
From: William Funk Planning Director/Zoning Inspector
Date: September 4, 2025
Re: Zoning Report for the month of August

Permits

During the month 17 zoning permits were issued in the following categories:

- Residential Addition 7
- Accessory Structure 7
- New Residential Dwelling 1
- Swimming Pool 1
- Fence 1

Zoning Commission

August 6, 2025, Zoning Commission public hearing and work session:

- The Zoning Commission reconvened their public on the proposed Ghent Interchange Overlay District. Ryan Smalley of Envision gave a presentation to the commission and outlined a sample site plan for how the area could be developed. The commission then postponed the public hearing until the September 11, 2025, meeting date. Following the public hearing the commission held a work session to continue the discussion on the draft of the overlay language.

Appearance Review Commission

August 4, 2025, the Appearance Review Commission reviewed the following cases:

- ARC 25-15, OLIO Development Group for Raising Cane's, tabled review of proposed signage for Raising Cane's at 3921 Medina Rd., located in the B-2 Business District.
- ARC 25-16, Tom Giltner for Corner Provisions, tabled review of proposed building signage for Corner Provisions at 1070 Ghent Rd., located in the B-1 Business District.

Board of Zoning Appeals

August 19, 2025, the Board of Zoning Appeals heard the following cases:

- BZA 25-17, Robert Newell, approved a conditional use request for an accessory dwelling unit and approved a variance to exceed the permitted area for the accessory dwelling unit at 3243 Yellow Creek Rd., located in the R-2 Residential District.
- BZA 25-20, Michelle Mapp, approved a variance to construct an accessory structure in the front yard at 616 Rotunda Ave., located in the R-2 Residential District.
- BZA 25-21, Mike Orley of Boulder Homes, tabled a variance request to encroach upon the riparian setback for a new residence at 4245 Cliff Spur Dr., located in the R-2 Residential District.

Solid Waste

- New Customers 16
- Vacation Customers 15
- Total Customers 3,427

Miscellaneous

- Bath Township is seeking volunteers to serve on the Comprehensive Plan Implementation Committee (CPIC)

Recommendations

- None



To: Board of Trustees
From: Vito F. Sinopoli, Township Administrator
Date: September 8, 2025
Re: Administrator's Report – 9/8/25

REPORT:

Construction has begun on the Bath Township portion of the I-77 widening project. The township has already seen an increase in automobile accidents in the construction zone. We urge residents to avoid the construction area when possible and to use caution and abide by all posted reductions in speed while traveling in the construction zones.

RECOMMENDATIONS:

1. Recommendation to approve the donation of \$1000 from the H.E. Graves, Jr. Family Foundation to the Bath Police Department for equipment and/or training needs.
2. Recommendation to contract with Hummel Construction Company for the Bath Township North Fork Preserve Barn Project, in the amount of \$1,489,130.00, which includes the Base and Alternate #1.



BATH TOWNSHIP DONATION APPLICATION

Complete if the application is on behalf of an individual.

Check box for Anonymous Donations

Name of Individual or Contact: _____

Address: _____

City: _____ State: _____ Zip: _____

Phone Number: _____ Email: _____

Complete if the application is on behalf of an entity.

Check box for Anonymous Donations

Name of Entity: The H.E. Graves, Jr. Family Foundation

Name of Individual making application on behalf of Entity: Keith & Michele Graves

Phone Number: 330-666-1115 Email: _____

Total Financial Donation(s) to Bath Township: \$ 1,000 to the Bath Police Department

Description of Non-Financial Donation: _____

Date of Donation(s): August 27, 2025

If the donation(s) is for any specific purpose, provide an explanation of the purpose(s) for which the donation(s) is being made: To be used for equipment and/or training.

**If additional space is needed, please attach additional sheets with this information to this form.*

Purpose of Entity: If commercial, please provide a description of the nature of the commercial enterprise(s) of the entity. If Not-For-Profit, please provide a description of the charitable causes supported:

Law enforcement.



The H. E. Graves, Jr. Family Foundation

TRUSTEES

S. Keith Graves
Michele A. Graves
Pamela Graves O'Neill
Patrick L. O'Neill

August 27, 2025

BATH POLICE DEPARTMENT
3864 W. BATH ROAD
AKRON OH 44333

Good Morning:

The Trustees of THE H. E. GRAVES, JR. FAMILY FOUNDATION are pleased to send you the enclosed donation in the amount of \$1,000 made payable to the "BATH POLICE DEPARTMENT".

Please use this donation for equipment and/or training.

We are happy to donate to such a worthwhile cause.

Sincerely,

Keith & Michele Graves

Keith & Michele Graves
Trustees

SKG/vs

Encl. - Ck. #2533

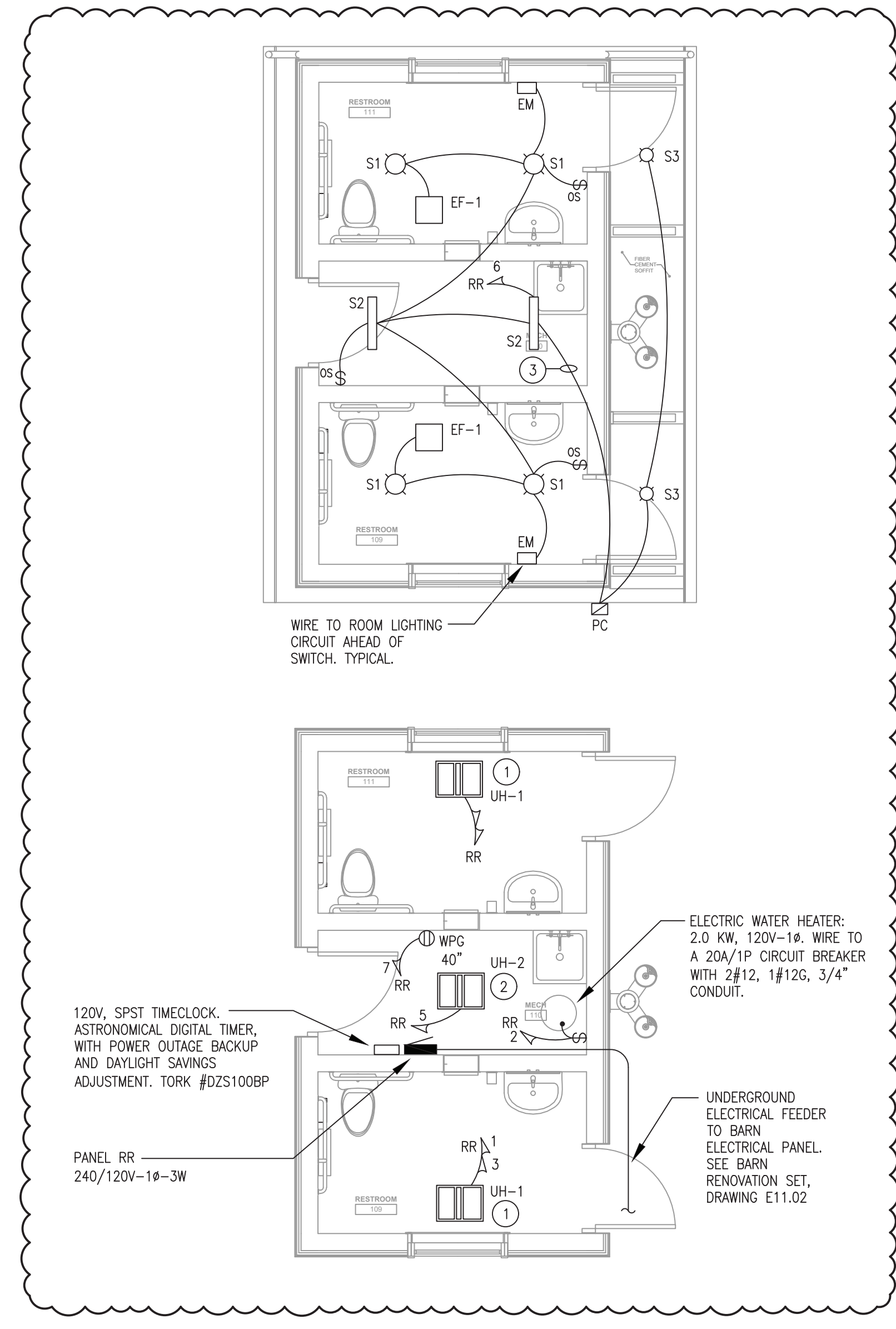

2 RESTROOM BUILDING ELECTRICAL PLANS
Scale: 1/4" = 1'-0"

- RESTROOM BUILDING ELECTRICAL CODED NOTES:**
- RECESSED ELECTRIC UNIT HEATER: 3.0 KW, 240V-1ϕ. EQUIPMENT IS PROVIDED WITH AN INTEGRAL DISCONNECT SWITCH. WIRE WITH 2#12, 1#12G, 3/4" CONDUIT TO A 20A/2P CIRCUIT BREAKER.
 - RECESSED ELECTRIC UNIT HEATER: 1.5 KW, 120V-1ϕ. EQUIPMENT IS PROVIDED WITH AN INTEGRAL DISCONNECT SWITCH.
 - ROUTE LIGHTING BRANCH CIRCUIT THROUGH LINE PHOTOCELL MOUNTED HIGH ON BUILDING.

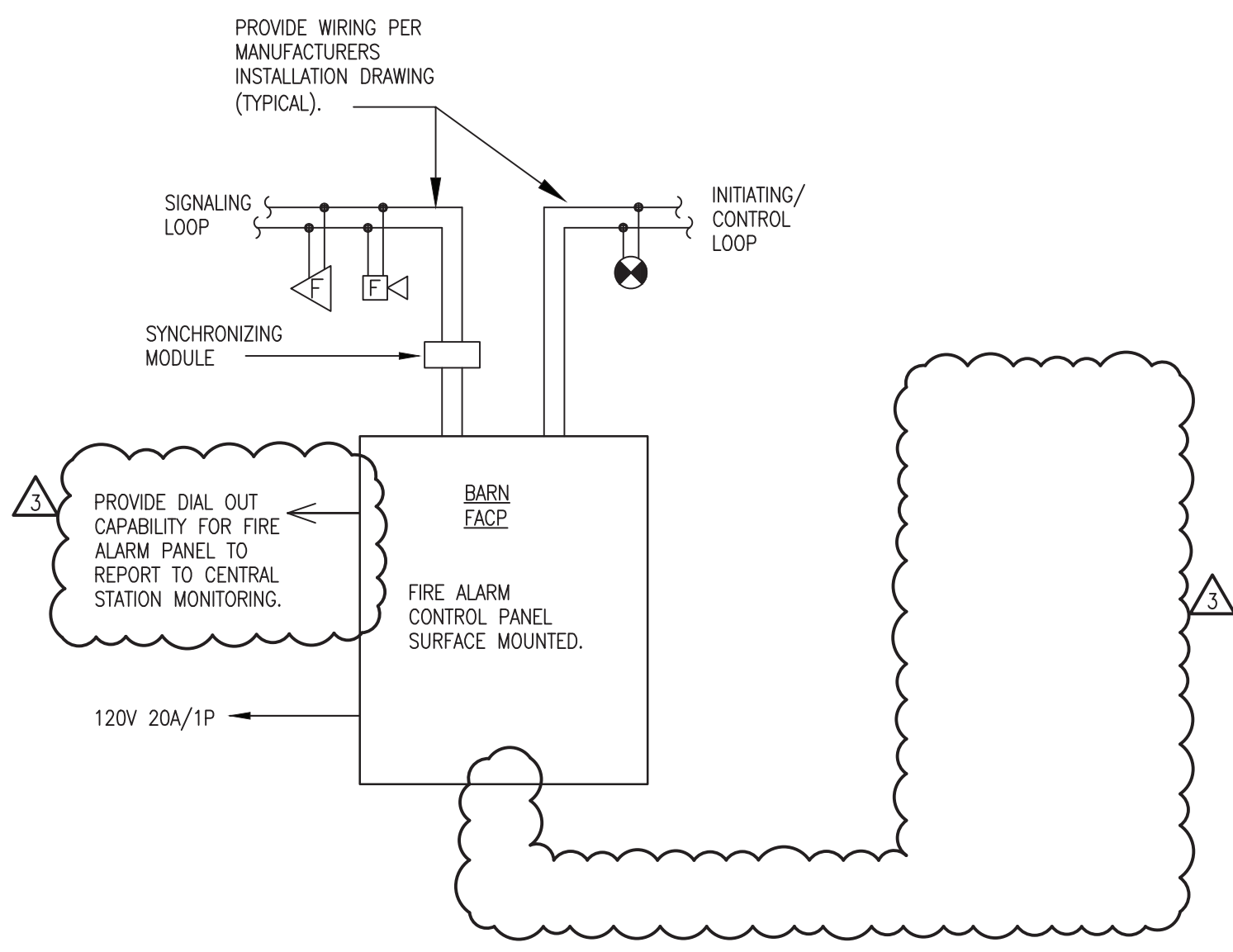

2 ADDRESSABLE FIRE ALARM SYSTEM RISER
Scale: NTS

- FIRE ALARM SYSTEM GENERAL NOTES:**
- THIS RISER REPRESENTS A TYPICAL SYSTEM AND IS NOT INTENDED FOR INSTALLATION. SYSTEM SUPPLIER SHALL PROVIDE INSTALLATION DRAWINGS AND SCHEMATIC WIRING DIAGRAMS. EXACT SYSTEM REQUIREMENTS SHALL BE COORDINATED WITH THE SYSTEM SUPPLIER. SYSTEM INSTALLER SHALL BE INCET CERTIFIED, IF REQUIRED BY LOCAL AUTHORITY HAVING JURISDICTION.
 - SYSTEM SUPPLIER SHALL SUPERVISE INSTALLATION, PROGRAM AND TEST SYSTEM AND INSTRUCT OWNER ON SYSTEM OPERATION.
 - ALL FIRE ALARM WIRING SHALL BE INSTALLED IN CONDUIT.
 - ALL CONTROL CABINETS SHALL BE GROUNDED PER NEC REQUIREMENTS AND PER SPECIFICATIONS.
 - FIRE ALARM SYSTEM DESIGNER SHALL BE RESPONSIBLE FOR ALL SHOP DRAWINGS, COORDINATION WITH OTHER TRADES AND INSTALLATION. SUBMIT PLANS FOR CITY TO REVIEW. PLANS SHALL INCLUDE DEVICE LOCATIONS ON SCALED FLOOR PLANS, WIRING INFORMATION AND DIAGRAMS, AND BATTERY CALCULATIONS.
 - ALL STROBES SHALL BE SYNCHRONIZED WITHIN LINE OF SIGHT. COORDINATE SCOPE IN THE FIELD AND WITH THE GENERAL CONTRACTOR.
 - FIRE ALARM SYSTEM SHALL BE THE SAME MANUFACTURER AS THE COMMUNITY CENTER.

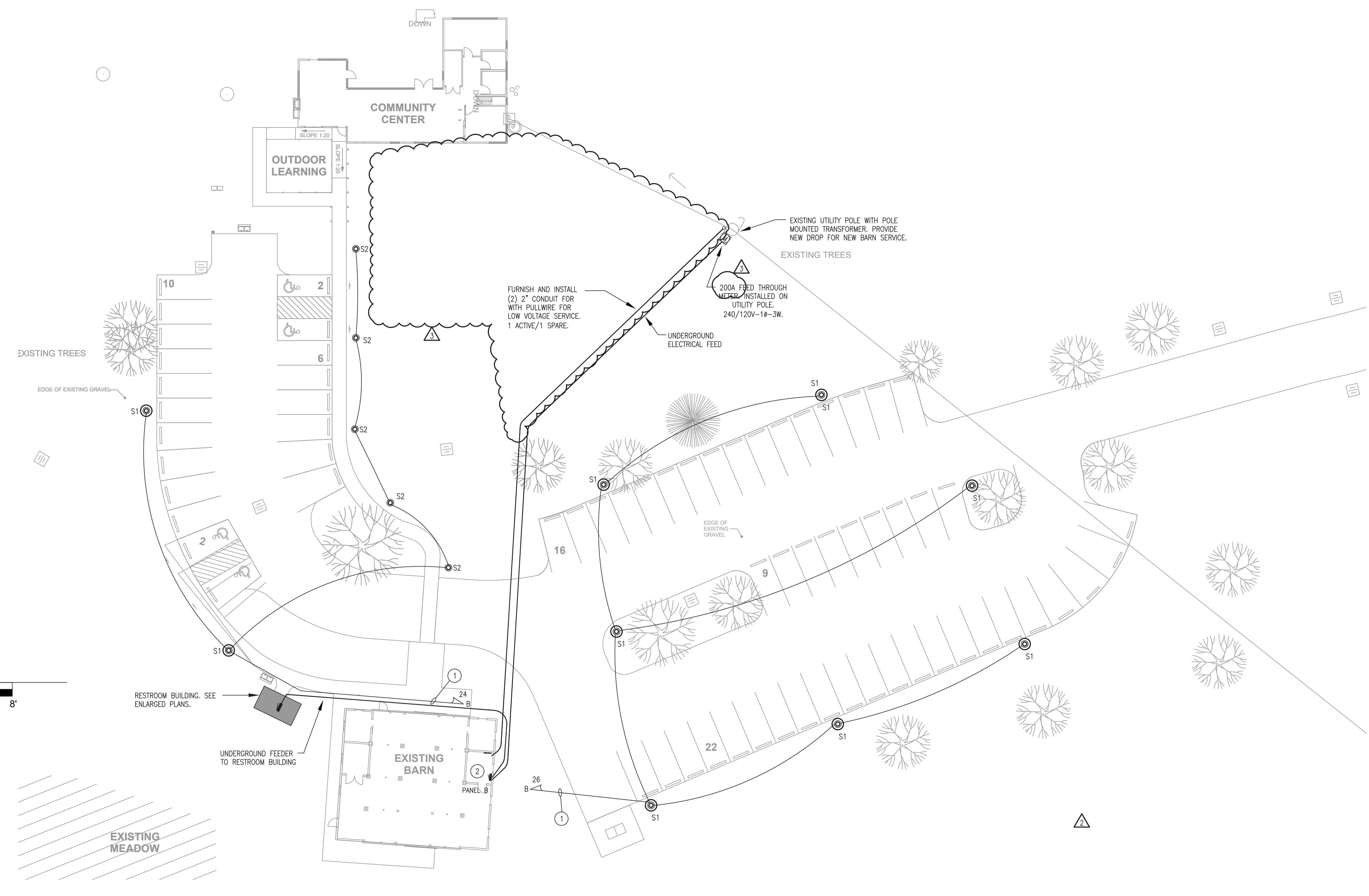

1 ELECTRICAL SITE PLAN
Scale: 1" = 20'

- ELECTRICAL SITE PLAN CODED NOTES:**
- 2#10, 1#10G, 3/4" PVC CONDUIT. 18" BELOW GRADE MINIMUM ROUTE THROUGH SITE LIGHTING TIMECLOCK.
 - PROVIDE 2 CIRCUIT TIMECLOCK WITH PHOTOCELL FOR PARKING LOT LIGHTING CIRCUITS. PHOTOCELL ON/TIMECLOCK OFF. SYSTEM SHALL BE CAPABLE OF INDEPENDENT TIME SETTINGS FOR EACH CIRCUIT.

SITE LIGHTING FIXTURE SCHEDULE				
TYPE	WATTAGE		DESCRIPTION	CATALOG #
	LAMP	FIXTURE		
S1	LED 3000K 9000L	80W	LED ROUND POST TOP FIXTURE MOUNTED ON 13" ROUND STEEL POLE	E-COINOUGHT C-LITE #C-AR-A=PTA-S9L-SCCT-UL-BZ POLE: RSS-13
S2	LED 3000K 4000L	37W	LED 36" TALL BOLLARD WITH 8" ROUND BASE AND DOME TOP	E-COINOUGHT C-LITE #C-BD-GRDD-DOME-SSL-SCCT-UL-BZ

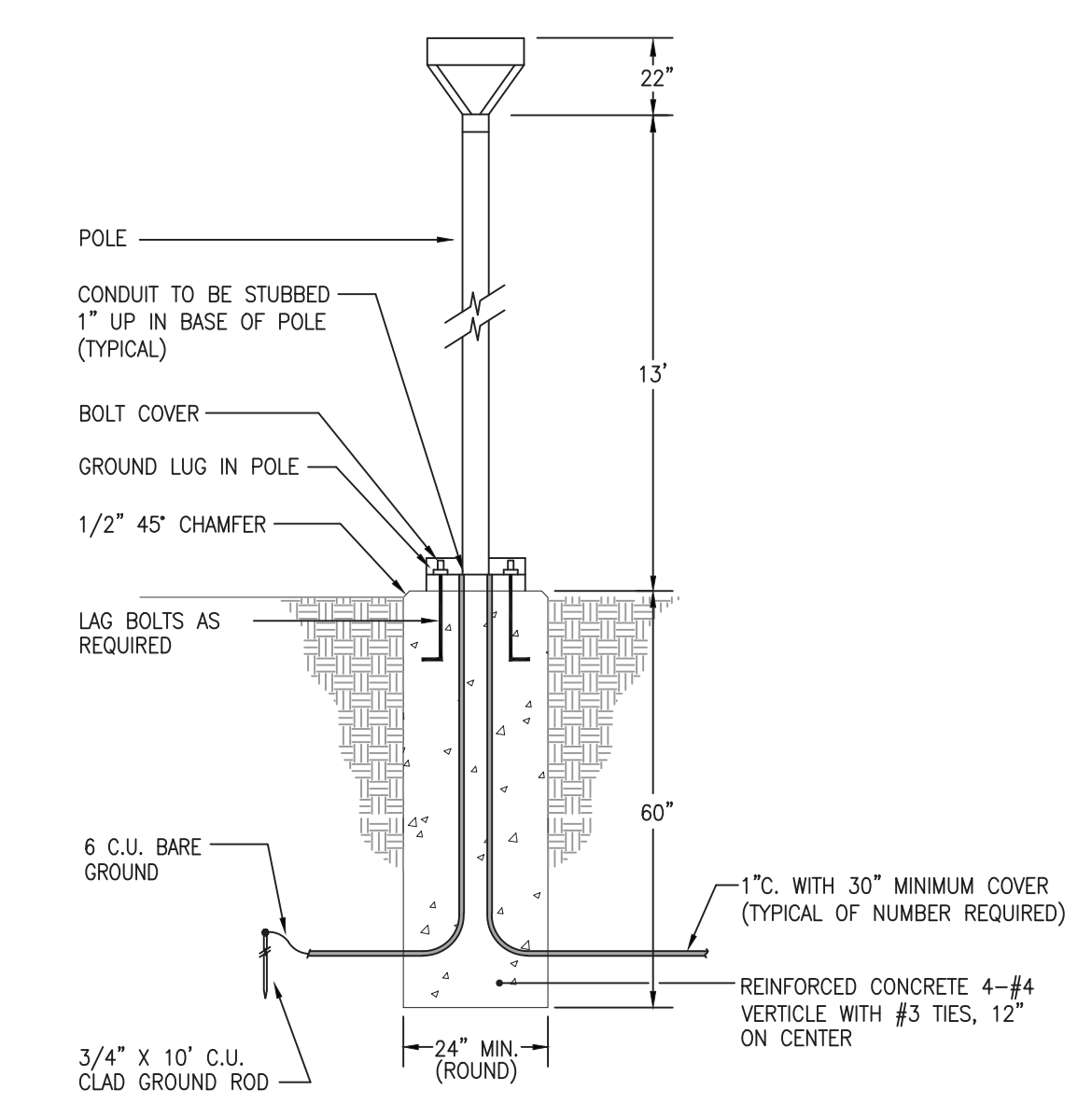

3 TYPE "S1" POLE BASE DETAIL
Scale: NTS

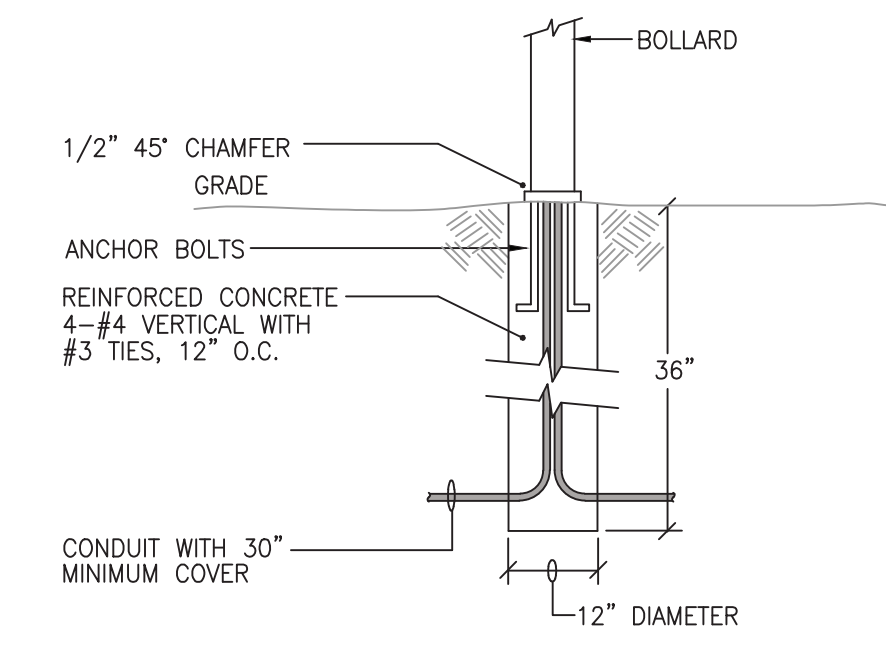

4 TYPE "S2" BOLLARD BASE DETAIL
Scale: NTS